

Potential of WDM packets

Dominique Chiaroni and Bogdan Uscumlic
Nokia Bell Labs, Route de Villejust, 91620 Nozay, France

Abstract— The need for ultra-low latencies in fronthaul/backhaul solutions for the 5G as well as the need for low energy consumption technologies in a cost-effective way push constructors of equipment to propose disruptive approaches for ICT. This paper will then draw the potential of WDM packets in terms of energy consumption and cost gains when compared to classical approaches. The study is completed with an additional analysis showing that this technology has the potential to efficiently reduce the insertion delay of networks.

Index Terms—5G, Add/Drop Multiplexer, Energy Efficiency, Optical Bypass, Optical Networks, WDM slots, Cross-haul technology

I. INTRODUCTION

THE ICT will have to enter into an in depth transformation to support a continuous traffic growth in a sustainable way. The energy consumption must be in the core of the preoccupations of any constructor of telecom equipment to provide a new generation of energy efficient products.

To reach this goal, many directions can be adopted:

- The first one is the eco-behavior at the subscriber side. New sensors are envisaged to minimize the energy consumption and this technology represents a potential research direction for the industry 4.0.
- The second one is the eco-design. It identifies new directions by selecting new components, new technologies, new systems and new network concepts in a disruptive way to significantly reduce the energy consumption.
- The third one is the eco-management. On the top of an eco-designed system, we can add a control to minimize its energy consumption during certain periods of time.
- The fourth one, is the self-powering exploiting renewable energies when possible to make the network element independent from the sources of energy produced at a country level.

In this paper, we focus on the eco-design of optical systems, and we will analyze the potential of an optical parallelism to reduce the cost and the energy consumption of network elements.

In a first part on this paper, we recall some tentative to introduce a parallelism in optical systems to reduce their energy consumption and cost.

In a second part, we analyze the potential of WDM packets, and in what network segments this technology could be of interest.

In a third part, we describe the two innovations proposed by the ANR N-GREEN project, and techno-economic studies illustrate how WDM packets can drop the cost of the hardware when compared to classical electronic approaches. A conclusion recalls the main messages and gives some perspectives.

II. PARALLELISM IN THE OPTICAL DOMAIN: NOT A NEW PARADIGM

The introduction of a parallelism in the optical processing has been considered a long time ago as a powerful approach to reduce cost and energy consumption of optical systems.

The most famous device is probably the flat gain Erbium Doped Fiber Amplifier (EDFA), enabling an amplification of a waveband to replace a battery of O/E/O regenerators. This was proposed for optical transmission systems, and it became rapidly a success, for the numerous advantages that this technology has provided. It was then possible to propose long haul all-optical submarine and terrestrial transmission systems while avoiding high frequency electronics in the transmission part of the systems.

The second scenario came from NTT, in the early 2000 through the proposal of Reconfigurable Optical Add/Drop Multiplexers (R-OADM) switching bands of wavelengths. The parallelism was identified as extremely efficient to reduce the CAPEX of Add/Drop systems. And many investigations were made from static waveband R-OADM to multi-granularity R-OADM [1] to process the channels first at the waveband level, then at the wavelength level and finally at the packet level. Since the circuit technology cannot accommodate constraining traffic profiles and a highly dynamic connectivity that can be required in metro networks the only solution to solve this problem is then to adopt multi-granularity R-OADM mixing optics and electronics technologies. This is not optimum in terms of cost and energy consumption.

The third scenario came from NICT [2], through the proposal

of WDM packets called also multicolor packets to transport high capacities over long distances. The packet technology has the potential to offer high network efficiencies and can support different traffic profiles. Optical packets are already a reality in xPON systems that have demonstrated their ability to minimize the energy consumption when compared to an ADSL technology. The proposal of WDM packets was identified as an interesting option by [2] when compared to classical optical packets encoded on one unique wavelength as illustrated in figure 1.

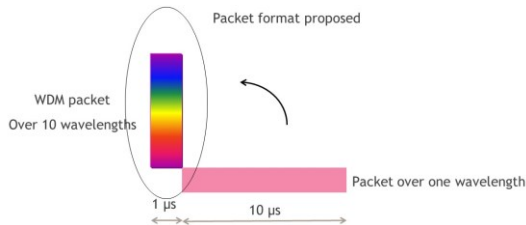

Figure 1: WDM packets: from time domain to (time + WDM) domain

To have a WDM packet, we first build a packet by aggregating different service data units, like Ethernet frames and we sample the packet to redistribute the data over N wavelengths as described. The result is that the WDM packet has a duration N times lower than the original packet, and is spread over N wavelengths (figure 1). The header is transported on one wavelength of the comb (in band header) or on another wavelength (out of band header). By adopting a WDM packet technology, we can have compact optical switching systems (Optical Add/Drop Multiplexer and optical switches), which reduces also the constraints of transmission by keeping the frequency of the data signals at lower values. However, this technology was mainly explored in the core of the network in [2] to boost the capacity of an optical network while preserving the distance of propagation.

In the ANR N-GREEN project, we investigated the WDM packets as a potential direction for cost sensitive network segments. We will then target mainly the access aggregation and the Cross-haul applications. In the following, we will list the different potential advantages of WDM packets.

III. POTENTIAL OF WDM PACKETS

WDM packets or multicolor packets should be considered as a new promising direction to reduce cost and energy consumption of network elements for the following reasons:

A. WDM packets are better exploiting the potential of optical technologies

One key characteristic of an optical switching technology, based on active or passive guides, is its ability to offer an exploitable optical bandwidth. If we can switch at the waveband level instead of a wavelength granularity the number of active switching elements becomes directly linked to the number of wavebands supported by the fiber and not to the number of wavelengths.

Therefore, WDM packets have then the potential to make the

transit systems more compact while maintaining the switching granularity at a constant value, not to impact the performance of the system. This makes a big difference with the circuit technology, impacting directly the switching granularity when bundling wavelengths. The key question is then: where do we need to adopt WDM packets?

B. Where WDM packets?

WDM packets, when used to transport high capacities, over different channels to reduce the frequency per channel, are not optimizing the spectral efficiency. However, since this spectral efficiency reduction could be compensated by a better network efficiency, WDM packets are also well suited for high capacity systems.

In the metro area, WDM packets, where the spectral efficiency is not an issue, become extremely attractive. We identify at least three uses cases, in a first introduction case, where WDM packets could be very efficient in optical systems: the access aggregation, the 5G cross-haul and the data centers (intra and inter connection).

C. Benefits of WDM packets?

WDM packets can provide new techno-economic advantages to optical systems when compared to single wavelength packets.

The advantages are listed below:

- *Towards low cost Transceivers (TRX):* WDM packets, require WDM transceivers [3], that can take benefit of the optical integration. When compared to a set of individual modules including only one laser, the WDM TRX can be cheaper and can offer lower power consumptions (only one Peltier instead of N).
- *Towards a simplified optical technology:* WDM packets simplify the optical technology. We don't need fast tunable lasers, or dedicated/complex devices to manage the traffic in transit. We can then more easily adopt components on the shelves or in the roadmap of component makers.
- *Towards cheaper Optical Add/Drop Multiplexers (OADM) structures:* WDM packets simplify the switching node structure. We effectively reduce the number of active optical switches by N (if N is the number of wavelengths used for the WDM packets) in the path through of OADM systems. It is an efficient technique to reduce the size of OADMs but also to reduce the physical connectivity of fast optical switches.
- *Towards lower frequency electronic systems:* WDM packets, by parallelizing the data, are slowing down the frequency in the electronic interfaces. There is no need for additional stages of time multiplexing. For example, a 100G TRX can operate at 10G, if we adopt a TRX based on 10x10G lasers and 10x10G photodiodes. We can then propose a more global solution, where the benefits are not only restricted to

the optical part but impact also to the electronic part.

- *Towards better network performance and easy upgrades:* WDM packets can offer a speed up, through a time compression helped by the WDM dimension added, which can offer a better system performance at the installation, a better control of the load evolution (not wavelength per wavelength, but sub-band per sub-band) to better anticipate the scalability and the upgradability.
- *Towards a new generation of programmable systems, SDN compliant:* WDM packets offer also an overprovisioning for free (the target cost of one WDM TRX module is roughly the price of three individual single wavelength TRX modules required to have a small overprovisioning at the installation), to enable programmable systems (we offer a higher capacity already installed in the network that can be managed by a centralized control plane like SDN).

WDM packets have then the potential to drive a new generation of low cost systems based on low cost components, better managed through a SDN control plane, and offering a better performance (an optical bypass suppresses intermediate buffering in a network) to support the 5G KPIs (multi-connectivity, x1000 capacity growth, 90% energy consumption reduction, and “zero” latency).

This is a pragmatic and competitive approach to envisage new product directions in cost sensitive areas (close to the access part) to offer a real dynamicity with a higher network efficiency.

IV. N-GREEN OBJECTIVES

The project N-GREEN project funded by the French National Research Agency (ANR) has been launched in January 2016 with the objective to propose two key innovations and targets a new generation of eco-designed systems.

The two innovations proposed are described in the following:

- A hybrid technology (circuit + packet), proposing a new WDM Slotted Add/Drop Multiplexer (WSADM) technology to integrate a L2 switch and a R-OADM technology into one integrated and low cost system. Figure 2 illustrates a node model including two optical technologies:
 - o One R-OADM based technology, to do flow switching, to establish static pipes, or to offer more security in the transport of data.
 - o One WSADM technology to support fast interconnection between distant data center or to dynamically interconnect nodes in a multi-point to multipoint configuration.
- A WDM modular and self-protected backplane as illustrated in figure 4 for the interconnection of line cards. WDM packets are here used to simplify the physical interconnection and to reduce the size of the switching part by adopting low connectivity switches. This new backplane, based on 16x16 optical switches

and 4x4 optical switches could offer internal switching capacities close to 1 Petabit in a simplified implementation scheme.

A. WDM slotted Add/Drop Multiplexer

The WDM Slotted Add/Drop Multiplexer (WSADM) is a very simple system based on reliable devices (optical couplers and mux/demux, SOAs and fixed lasers & fixed receivers), targeting a new generation of products offering the requirements of many network segments. It is proposed for the access aggregation, Cross-haul and potentially data centers, but also, in a second step, for the metro core and the backbone when adopting Nx100G TRX. In that last use case, the poor spectral efficiency is compensated by a higher network efficiency. The N-GREEN concept, by adopting sub-bands of 10 wavelengths is fully compatible with a flexgrid technology, through a proper sharing of the optical bandwidth (as illustrated in figure 3).

Therefore, we could adopt the N-GREEN technology in the network segments closer to the access part to offer a real alternative to the electronic Ethernet technology. The N-GREEN technology could be then adopted in a national backbone to offer a dynamic technology on the top of the flexgrid technology to offer new services.

Figure 3 shows a spectrum sharing per sub-bands to multiplex the N-GREEN technology when required.

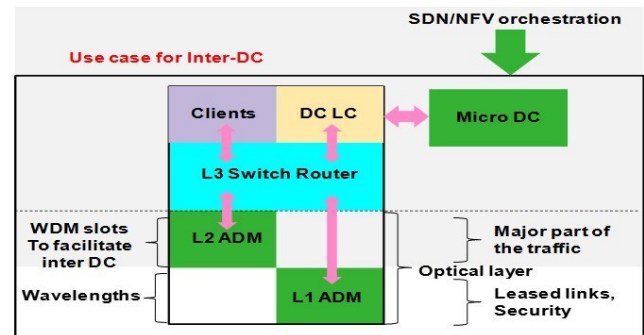

Figure 2: N-GREEN concept. WDM slots are envisaged as a complementary solution to the flexgrid technology

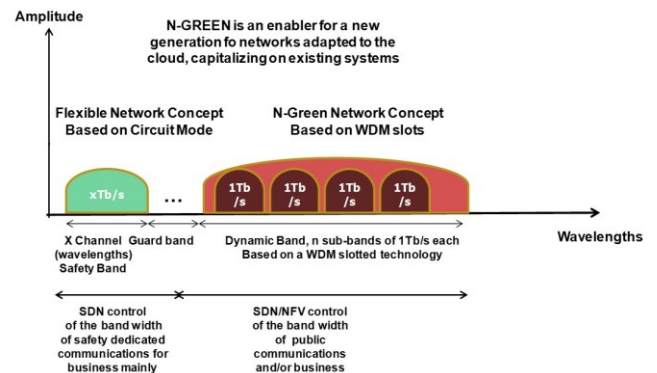

Figure 3: Spectrum sharing, to include the N-GREEN technology on the top of an already deployed optical technology, like the flexgrid technology

We propose here to have two technologies: one flexgrid

technology to transport a high capacity with a stable traffic matrix; one packet technology to support a highly dynamic traffic like the interconnection of distant data centers.

B. WDM modular self-protected backplane.

The WDM packet technology has been also proposed in the N-GREEN project for the simplification of the backplane when targeting switching capacities exceeding 100 Tbit/s. The adoption of highly compact fast optical switching technologies is an enabler to support a protection scheme at a low cost.

The WDM packets allow here a simplification of the fiber interconnection with the switching stages of the backplane. Typically, we have to manage 10's of fibers instead of 1000's of fibers.

Finally, the WDM packets, allows a strong improvement of the energy efficiency used to switch the traffic. In our case, the energy efficiency for the optical switches is quite high since we need only 100 femtoJoules to switch 1 bit.

Figure 4 illustrates the backplane under study. The objective is to aggregate the traffic at two levels: first in the time domain at 1Tbit/s using 10 μ s slots, and secondly in the WDM domain by adopting a shift register to transform one 10 μ s slot into 10 1 μ s slots. The WDM packets are then switched in the optical domain, to fully exploit the optical bandwidth of optical switches to reach terabits of switching capacity. The reliability is increased and the complexity of the system could be dramatically reduced.

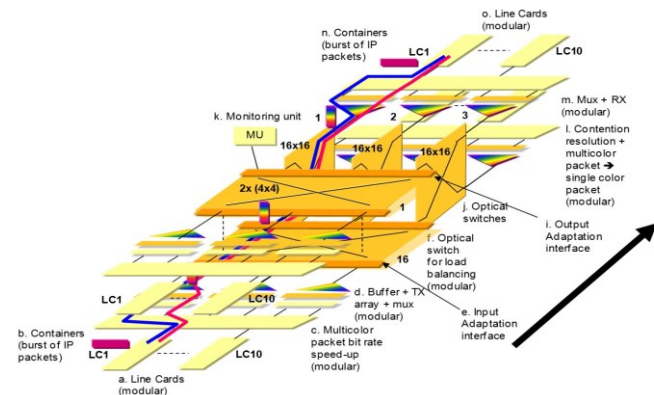

Figure 4: WDM modular and self-protected backplane

This WDM modular and self-protected backplane operates as follows:

- The client data, from the line cards of the Switch/Router, are, in a first step, aggregated in a slot of 10 μ s at 1 Tbit/s. Each line card manages a number of slots equal to the number of destinations (16 in our case).
- In a second step, a shift register is used to redistribute the data over ten buffers, themselves interconnected to the Nx1T sources. The buffer is mainly used to solve the contention.
- When validated by the scheduler, the WDM packet is send in the 4x4 WDM switch responsible for the load balancing. A 1+1 4x4 switch is used in this first

switching stage, to enable a protection path in case of a failure of the main 4x4 switch.

- The WDM packet is then sent to the 16x16 optical switch to reach its destination line card. Three stages of 16x16 optical switches are used in parallel to maintain the average load per switching plane close to 33.3 %. In case of a failure of one switching stage, the traffic is then shared between two switching stages instead of three. This guarantees an active protection, in case of a failure of one switching stage.
- The WDM packets are then stored into buffers, before their re-transformation in the time domain.
- The slots of 10 μ s are finally processed to extract the client packets that will be sent to the destination line card.

V. RESULTS OF THE WDM SLOTTED ADD/DROP MULTIPLEXER

During the first year of the project, we focused our studies on techno-economic studies, to demonstrate that the technology proposed is cost effective and less power consuming than an Ethernet technology.

Figure 5 describes the Packet Optical Add/Drop Multiplexer (POADM) structure and the WSADM structure. At full capacity, the WSADM requires 10x less optical gates for the management of the transit traffic than for the POADM structure. In addition, at full capacity, the WSADM requires one integrated WDM TRX whereas the POADM architecture requires 10 Tunable lasers and Tunable receivers in its optimized version.

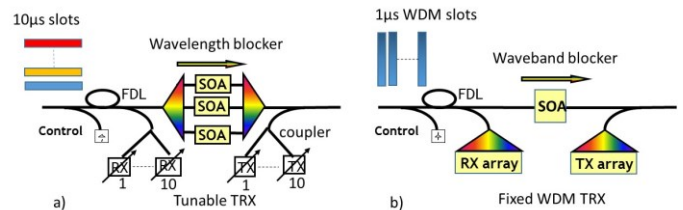

Figure 5: a) POADM, b) WSADM

Figure 6 describes the difference between the WSADM technology and the Ethernet technology. We split the model of the node into four parts: the TRX, the line cards, the switch and the scheduler. This model will be used for the techno-economic studies presented in figure 7 and 8.

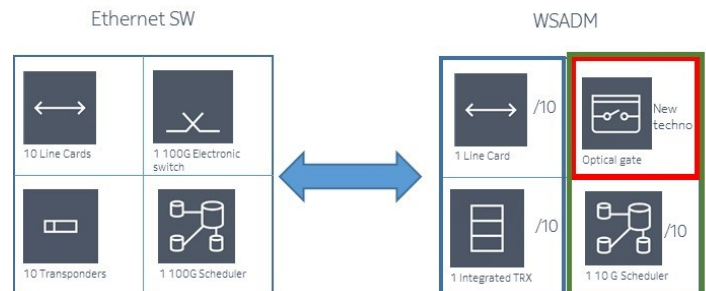

Figure 6: model of the node considered

Figure 7 illustrates the cost evolution (CAPEX and OPEX) of the proposed WSADM technology for a network of 10 nodes benchmarked with the Ethernet technology. We observe that WDM packets reduce CAPEX & OPEX while preserving a competitive introduction cost.

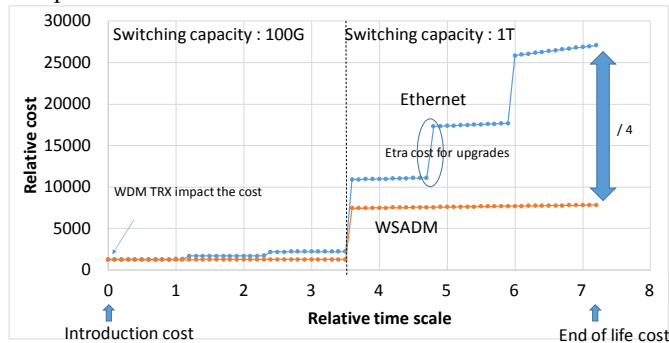

Figure 7: WSADM (WDM packet-based ADM systems) technology vs Ethernet systems through a CAPEX & OPEX analysis

Figure 8 illustrates the energy savings obtained through a reduction of the CO₂ emissions by a factor 3 at the end of life time of a node.

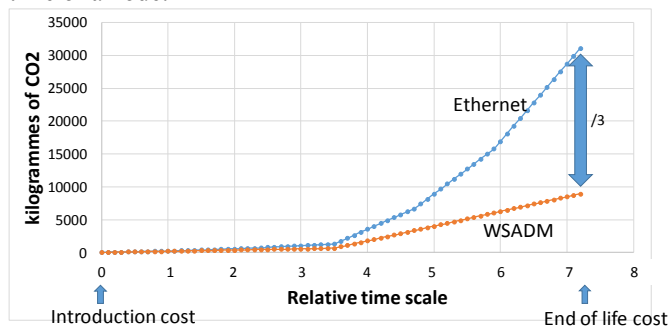

Figure 8: Emission of CO₂, comparing two types of 100G nodes: a 100G WSADM and a 100G Ethernet Switch.

Figure 9, shows the insertion latency evolution versus the channel occupancy (the channel is defined as a virtual resource that can be a single wavelength slot or a multi-wavelength slot). We observe that the dimensional transformation from time to time plus wavelength improves dramatically the average insertion latency.

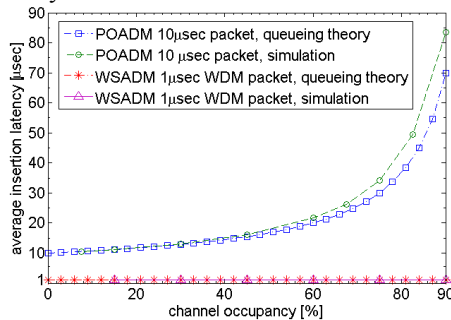

Figure 9: Insertion latency at one node vs the channel occupancy of the optical bus. The insertion latency can be 10 times less for the WSADM vs the POADM technology.

This last result demonstrates that WDM packets have the potential, in addition to cost gains, through a capitalization on TRX coming from the DATA COM or from the NGPON2 community, and energy savings, to offer very low latencies.

This new technology is then a potential candidate for a new generation of packet networks in particular for heterogeneous networks supporting 4G and 5G technologies where ultra-small latencies are required or for access aggregation network segments where the cost is a key issue.

In a second step, it could be interesting to analyze the potential of WDM packet in metro core and backbones using WDM optical buses and verify that the WDM packet technology through a higher network efficiency could compensate the reduce spectral efficiency with some gains.

These preliminary results indicate that WDM packets could be an enabler to drive a new generation of low cost effective optical systems and networks and really open new research directions.

VI. CONCLUSION

Helped by the emergence of DATA COM technologies, for the TRX parts, WDM packets could become a pragmatic direction to design low cost systems based on access/ data com components and taking benefit of the natural potential of optical technologies: their capabilities to offer wide optical bandwidths. This paper by proposing a new direction to realize low cost optical systems in a sustainable way while offering new perspectives in terms of latency creates new opportunities for the network.

A first analysis demonstrates that a better exploitation of the WDM dimension, at a constant switching granularity, could be the solution to realize cheap systems and small emission of CO₂ when compared to classical Ethernet technologies. A second study based on the performance analysis shows that WDM packet based systems could provide a better performance when compared to a single channel approach.

For the previous reasons, WDM packets could play then on important role in the next decade to propose disruptive solutions for different network segments, in a sustainable way.

ACKNOWLEDGMENTS

The authors thank the ANR, the poles of competitiveness "Systematic" and "Images et Réseaux" for their support and the partial funding. The authors thank also all the partners of the N-GREEN project for the fruitful discussions, and the collaborative work.

REFERENCES

- [1] Kiyoo Ishii, Osamu Moriwaki, Hiroshi Hasegawa, Ken-Ichi Sato, Yoshiteru Jimnouchi, Masayuki Okuno, Hiroshi Takahashi, "Efficient ROADM-ring connecting node switch architecture that utilizes waveband routing and its realization with PLC technologies," in ECOC 2009, Sept. 2009.
- [2] Naoya Wada, "WDM-colored Packet Switching," OFC/NFOEC 2008, OWL1, 978-1-55752-855-1/08. San Diego, USA, Feb. 2008
- [3] Robert Hughes, Effect Photonics, ECOC 2016. Düsseldorf, Germany, September 2016.

